

Geometry

Released Test Questions

1 Which of the following best describes deductive reasoning?

- A using logic to draw conclusions based on accepted statements
- B accepting the meaning of a term without definition
- C defining mathematical terms to correspond with physical objects
- D inferring a general truth by examining a number of specific examples

CSG00185

2 In the diagram below, $\angle 1 \cong \angle 4$.

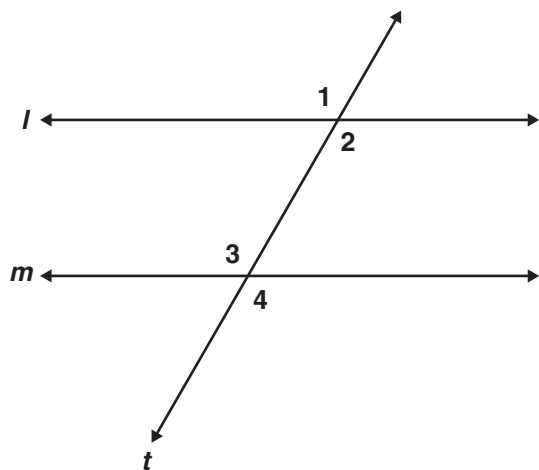

Which of the following conclusions does *not* have to be true?

- A $\angle 3$ and $\angle 4$ are supplementary angles.
- B Line l is parallel to line m .
- C $\angle 1 \cong \angle 3$
- D $\angle 2 \cong \angle 3$

CSG10066

3 Consider the arguments below.

- I. Every multiple of 4 is even. 376 is a multiple of 4. Therefore, 376 is even.
- II. A number can be written as a repeating decimal if it is rational. Pi cannot be written as a repeating decimal. Therefore, pi is not rational.

Which one(s), if any, use deductive reasoning?

- A I only
- B II only
- C both I and II
- D neither I nor II

CSG00552

4 Theorem: A triangle has at most one obtuse angle.

Eduardo is proving the theorem above by contradiction. He began by assuming that in $\triangle ABC$, $\angle A$ and $\angle B$ are both obtuse. Which theorem will Eduardo use to reach a contradiction?

- A If two angles of a triangle are equal, the sides opposite the angles are equal.
- B If two supplementary angles are equal, the angles each measure 90° .
- C The largest angle in a triangle is opposite the longest side.
- D The sum of the measures of the angles of a triangle is 180° .

CSG00025

- 5 Use the proof to answer the question below.

Given: $\overline{AB} \cong \overline{BC}$; D is the midpoint of \overline{AC}

Prove: $\triangle ABD \cong \triangle CBD$

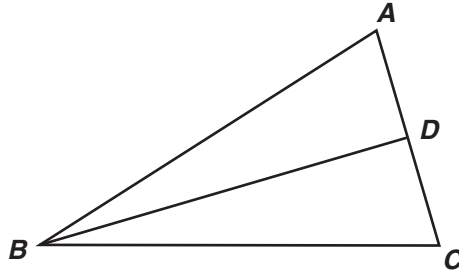

<u>Statement</u>	<u>Reason</u>
1. $\overline{AB} \cong \overline{BC}$; D is the midpoint of \overline{AC}	1. Given
2. $\overline{AD} \cong \overline{CD}$	2. Definition of Midpoint
3. $\overline{BD} \cong \overline{BD}$	3. Reflexive Property
4. $\triangle ABD \cong \triangle CBD$	4. ?

What reason can be used to prove that the triangles are congruent?

- A AAS
- B ASA
- C SAS
- D SSS

Geometry

Released Test Questions

- 6 In the figure below, $AB > BC$.

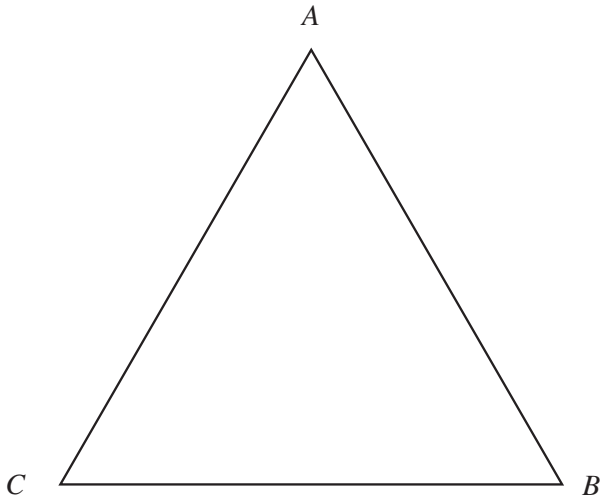

If we assume that $m\angle A = m\angle C$, it follows that $AB = BC$. This contradicts the given statement that $AB > BC$. What conclusion can be drawn from this contradiction?

- A $m\angle A = m\angle B$
- B $m\angle A \neq m\angle B$
- C $m\angle A = m\angle C$
- D $m\angle A \neq m\angle C$

CSG00524

- 7 Use the proof to answer the question below.

Given: $\angle 2 \cong \angle 3$

Prove: $\angle 1 \cong \angle 4$

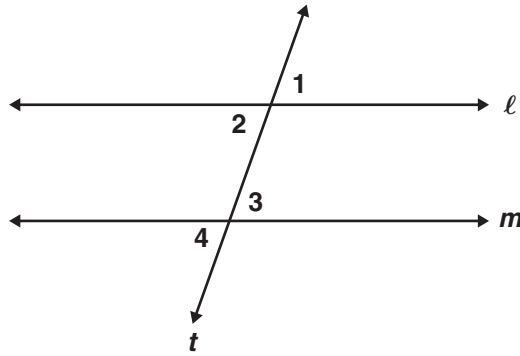

<u>Statement</u>	<u>Reason</u>
1. $\angle 2 \cong \angle 3$	1. Given
2. $\angle 1 \cong \angle 2; \angle 3 \cong \angle 4$	2. ?
3. $\angle 1 \cong \angle 4$	3. Transitive Property

What reason can be used to justify statement 2?

- A Complements of congruent angles are congruent.
- B Vertical angles are congruent.
- C Supplements of congruent angles are congruent.
- D Corresponding angles are congruent.

Geometry

Released Test Questions

- 8 “Two lines in a plane always intersect in exactly one point.”

Which of the following best describes a counterexample to the assertion above?

- A coplanar lines
- B parallel lines
- C perpendicular lines
- D intersecting lines

CSG00320

- 9 Which figure can serve as a counterexample to the conjecture below?

If one pair of opposite sides of a quadrilateral is parallel, then the quadrilateral is a parallelogram.

- A rectangle
- B rhombus
- C square
- D trapezoid

CSG10194

- 10 Given: $TRAP$ is an isosceles trapezoid with diagonals \overline{RP} and \overline{TA} . Which of the following *must* be true?

- A $\overline{RP} \perp \overline{TA}$
- B $\overline{RP} \parallel \overline{TA}$
- C $\overline{RP} \cong \overline{TA}$
- D \overline{RP} bisects \overline{TA}

CSG00260

- 11 A conditional statement is shown below.

If a quadrilateral has perpendicular diagonals, then it is a rhombus.

Which of the following is a counterexample to the statement above?

A

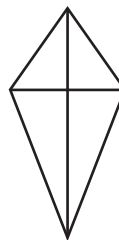

C



B

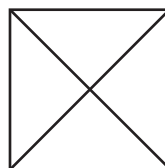

D

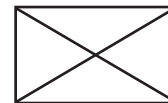

CSG20216

Released Test Questions

Geometry

12 Which triangles must be similar?

- A two obtuse triangles
- B two scalene triangles with congruent bases
- C two right triangles
- D two isosceles triangles with congruent vertex angles

CSG00578

13 Which of the following facts would be sufficient to prove that triangles ABC and DBE are similar?

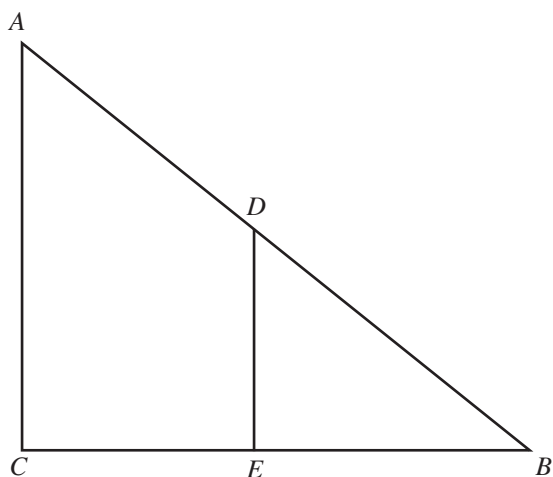

- A \overline{CE} and \overline{BE} are congruent.
- B $\angle ACE$ is a right angle.
- C \overline{AC} and \overline{DE} are parallel.
- D $\angle A$ and $\angle B$ are congruent.

CSG00544

14 Parallelogram $ABCD$ is shown below.

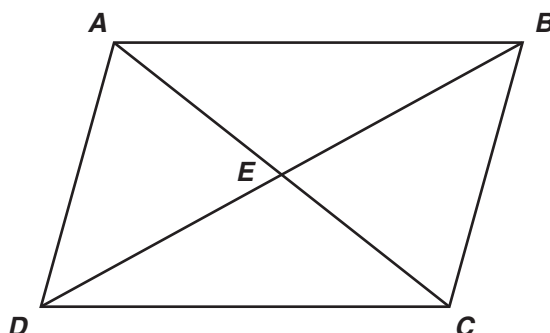

Which pair of triangles can be established to be congruent to prove that $\angle DAB \cong \angle BCD$?

- A $\triangle ADC$ and $\triangle BCD$
- B $\triangle AED$ and $\triangle BEC$
- C $\triangle DAB$ and $\triangle BCD$
- D $\triangle DEC$ and $\triangle BEA$

CSG10146

15 If $\triangle ABC$ and $\triangle XYZ$ are two triangles such that $\frac{AB}{XY} = \frac{BC}{YZ}$, which of the following would be sufficient to prove the triangles are similar?

- A $\angle A \cong \angle X$
- B $\angle B \cong \angle Y$
- C $\angle C \cong \angle Z$
- D $\angle X \cong \angle Y$

CSG10218

Geometry

Released Test Questions

- 16** In parallelogram $FGHI$, diagonals \overline{IG} and \overline{FH} are drawn and intersect at point M . Which of the following statements *must* be true?

- A $\triangle FGI$ must be an obtuse triangle.
- B $\triangle HIG$ must be an acute triangle.
- C $\triangle FMG$ must be congruent to $\triangle HMG$.
- D $\triangle GMH$ must be congruent to $\triangle IMF$.

CSG00559

- 17** Which of the following *best* describes the triangles shown below?

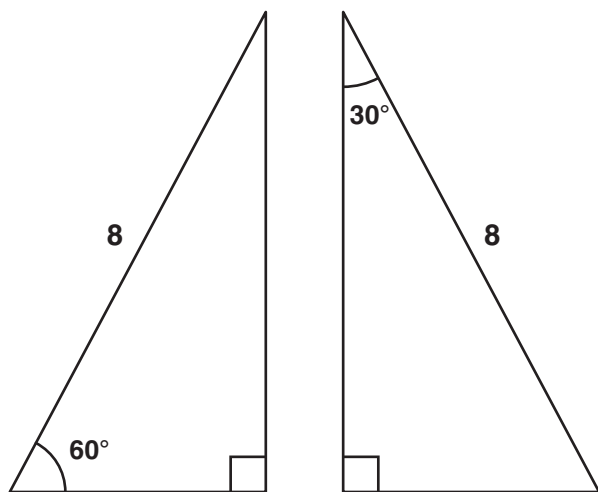

- A both similar and congruent
- B similar but not congruent
- C congruent but not similar
- D neither similar nor congruent

CSG00478

- 18** Which of the following statements must be true if $\triangle GHI \sim \triangle JKL$?

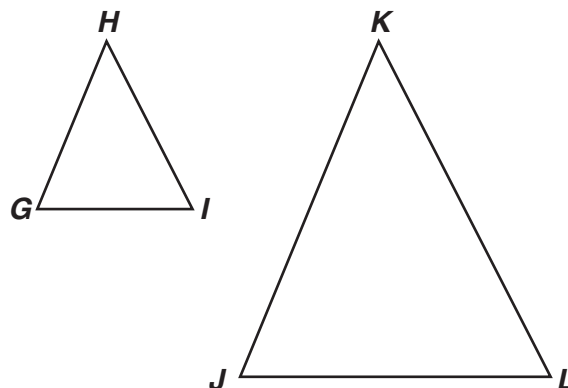

- A The two triangles must be scalene.
- B The two triangles must have exactly one acute angle.
- C At least one of the sides of the two triangles must be parallel.
- D The corresponding sides of the two triangles must be proportional.

CSG20074

Released Test Questions

Geometry

- 19 In the figure below, $\overline{AC} \cong \overline{DF}$ and $\angle A \cong \angle D$.

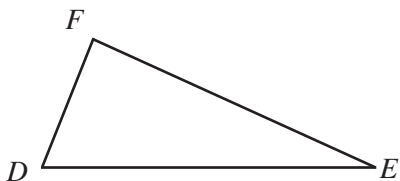
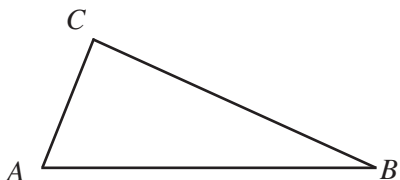

Which additional information would be enough to prove that $\triangle ABC \cong \triangle DEF$?

- A $\overline{AB} \cong \overline{DE}$
- B $\overline{AB} \cong \overline{BC}$
- C $\overline{BC} \cong \overline{EF}$
- D $\overline{BC} \cong \overline{DE}$

CSG00517

- 20 Given: \overline{AB} and \overline{CD} intersect at point E ;
 $\angle 1 \cong \angle 2$

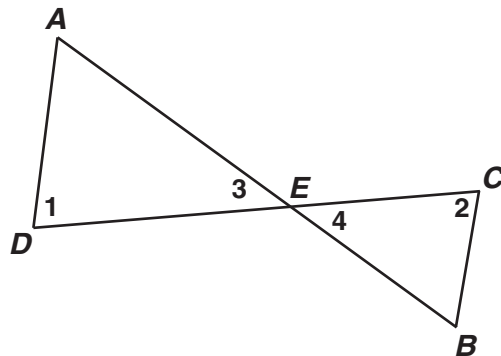

Which theorem or postulate can be used to prove $\triangle AED \sim \triangle BEC$?

- A AA
- B SSS
- C ASA
- D SAS

CSG10074

- 21 In the figure below, n is a whole number. What is the *smallest* possible value for n ?

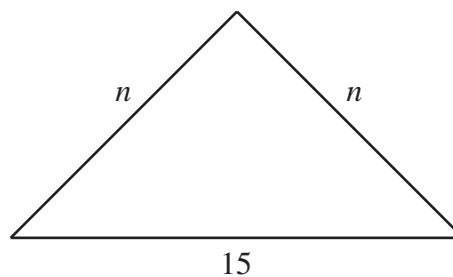

- A 1
- B 7
- C 8
- D 14

CSG00295

Geometry

Released Test Questions

- 22** Which of the following sets of numbers could represent the lengths of the sides of a triangle?

- A 2, 2, 5
- B 3, 3, 5
- C 4, 4, 8
- D 5, 5, 15

CSG10041

- 23** In the accompanying diagram, parallel lines l and m are cut by transversal t .

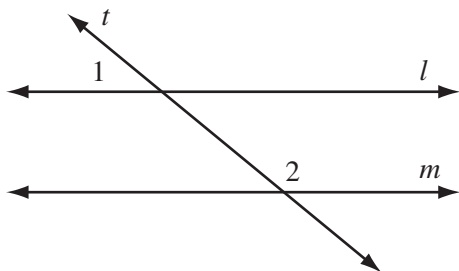

Which statement about angles 1 and 2 *must* be true?

- A $\angle 1 \cong \angle 2$.
- B $\angle 1$ is the complement of $\angle 2$.
- C $\angle 1$ is the supplement of $\angle 2$.
- D $\angle 1$ and $\angle 2$ are right angles.

CSG00579

- 24** What values of a and b make quadrilateral $MNOP$ a parallelogram?

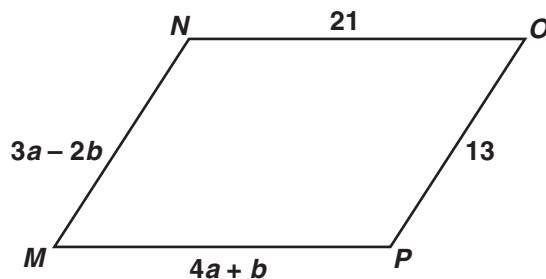

- A $a = 1, b = 5$
- B $a = 5, b = 1$
- C $a = \frac{11}{7}, b = \frac{34}{7}$
- D $a = \frac{34}{7}, b = \frac{11}{7}$

CSG10163

- 25** Quadrilateral $ABCD$ is a parallelogram. If adjacent angles are congruent, which statement *must* be true?

- A Quadrilateral $ABCD$ is a square.
- B Quadrilateral $ABCD$ is a rhombus.
- C Quadrilateral $ABCD$ is a rectangle.
- D Quadrilateral $ABCD$ is an isosceles trapezoid.

CSG20048

Released Test Questions

Geometry

- 26 For the quadrilateral shown below, what is $m\angle a + m\angle c$?

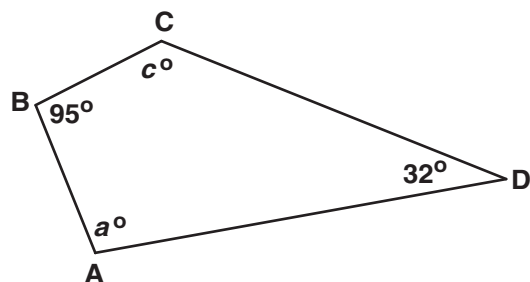

- A 53°
 B 137°
 C 180°
 D 233°

CSG10162

- 27 If $ABCD$ is a parallelogram, what is the length of segment BD ?

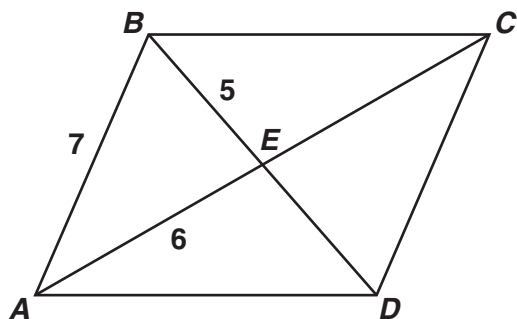

- A 10
 B 11
 C 12
 D 14

CSG20236

- 28 A right circular cone has radius 5 inches and height 8 inches.

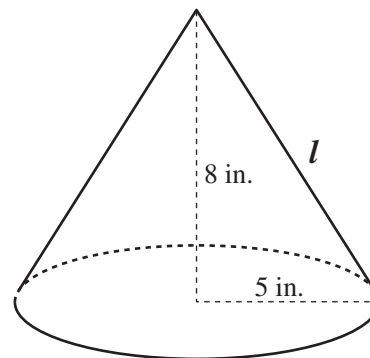

What is the lateral area of the cone? (Lateral area of cone = πrl , where l = slant height)

- A 40π sq in.
 B 445π sq in.
 C $5\pi\sqrt{39}$ sq in.
 D $5\pi\sqrt{89}$ sq in.

CSG00053

Geometry

Released Test Questions

- 29** Figure $ABCD$ is a kite.

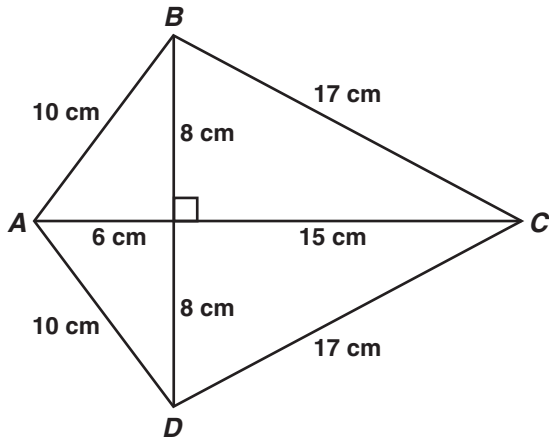

What is the area of figure $ABCD$, in square centimeters?

- A 120
- B 154
- C 168
- D 336

CSG20157

- 30** If a cylindrical barrel measures 22 inches in diameter, how many inches will it roll in 8 revolutions along a smooth surface?

- A 121π in.
- B 168π in.
- C 176π in.
- D 228π in.

CSG00564

- 31** A sewing club is making a quilt consisting of 25 squares with each side of the square measuring 30 centimeters. If the quilt has five rows and five columns, what is the perimeter of the quilt?

- A 150 cm
- B 300 cm
- C 600 cm
- D 900 cm

CSG20111

- 32** The four sides of this figure will be folded up and taped to make an open box.

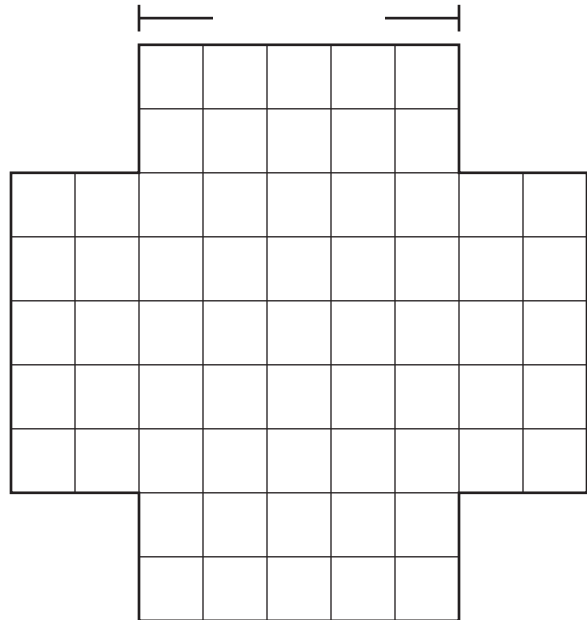

What will be the volume of the box?

- A 50 cm^3
- B 75 cm^3
- C 100 cm^3
- D 125 cm^3

CSG00299

Released Test Questions

Geometry

- 33** A classroom globe has a diameter of 18 inches.



Which of the following is the approximate surface area, in square inches, of the globe?
(Surface Area = $4\pi r^2$)

- A 113.0
- B 226.1
- C 254.3
- D 1017.4

CSG20238

- 34** The rectangle shown below has length 20 meters and width 10 meters.

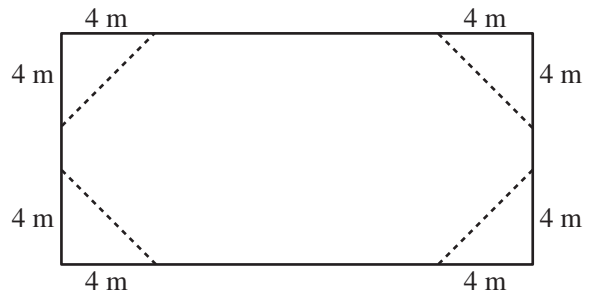

If four triangles are removed from the rectangle as shown, what will be the area of the remaining figure?

- A 136 m^2
- B 144 m^2
- C 168 m^2
- D 184 m^2

CSG00012

- 35** If $RSTW$ is a rhombus, what is the area of $\triangle WXT$?

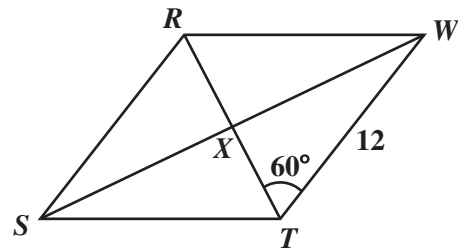

- A $18\sqrt{3}$
- B $36\sqrt{3}$
- C 36
- D 48

CSG00027

Geometry

Released Test Questions

- 36** What is the area, in square units, of the trapezoid shown below?

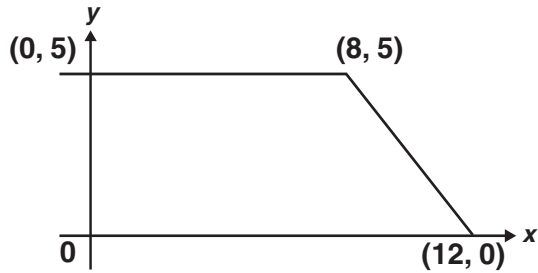

- A 37.5
- B 42.5
- C 50
- D 100

CSG20226

- 37** The figure below is a square with four congruent parallelograms inside.

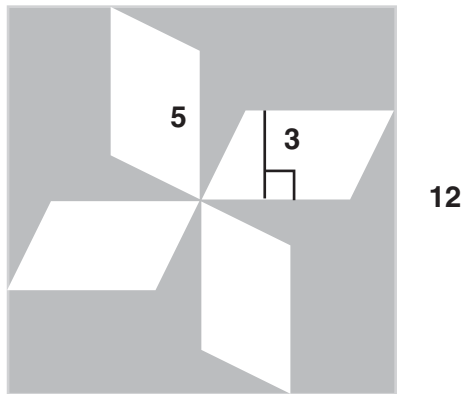

What is the area, in square units, of the shaded portion?

- A 60
- B 84
- C 114
- D 129

CSG20225

- 38** What is the area, in square meters (m), of the trapezoid shown below?

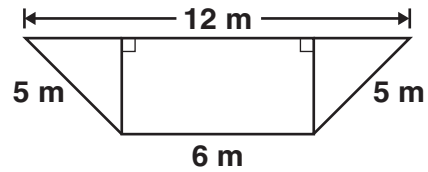

- A 28
- B 36
- C 48
- D 72

CSG10047

- 39** What is the area, in square inches (in.), of the triangle below?

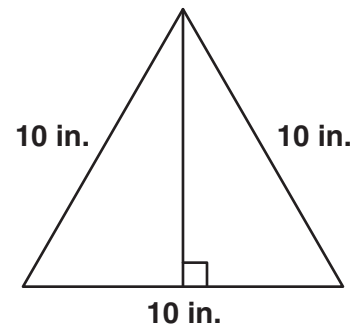

- A 25
- B $25\sqrt{3}$
- C 50
- D $50\sqrt{3}$

CSG10048

Released Test Questions

Geometry

- 40** The perimeters of two squares are in a ratio of 4 to 9. What is the ratio between the areas of the two squares?

A 2 to 3
 B 4 to 9
 C 16 to 27
 D 16 to 81

CSG00013

- 41** Lea made two candles in the shape of right rectangular prisms. The first candle is 15 cm high, 8 cm long, and 8 cm wide. The second candle is 5 cm higher but has the same length and width. How much additional wax was needed to make the taller candle?

A 320 cm^3
 B 640 cm^3
 C 960 cm^3
 D 1280 cm^3

CSG20116

- 42** Two angles of a triangle have measures of 55° and 65° . Which of the following could *not* be a measure of an exterior angle of the triangle?

A 115°
 B 120°
 C 125°
 D 130°

CSG00571

- 43** The sum of the interior angles of a polygon is the same as the sum of its exterior angles. What type of polygon is it?

A quadrilateral
 B hexagon
 C octagon
 D decagon

CSG00305

- 44** What is $m\angle x$?

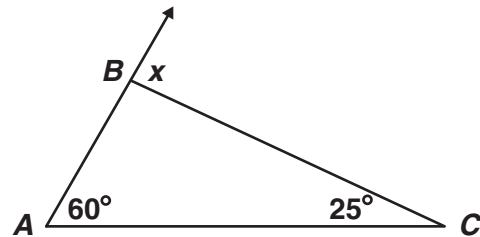

A 35°
 B 60°
 C 85°
 D 95°

CSG20086

- 45** If the measure of an exterior angle of a regular polygon is 120° , how many sides does the polygon have?

A 3
 B 4
 C 5
 D 6

CSG20204

Geometry

Released Test Questions

- 46** In the figure below, $\overline{AB} \parallel \overline{CD}$.

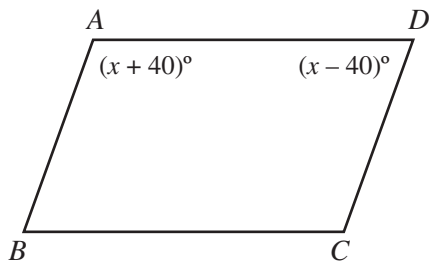

What is the value of x ?

- A 40
- B 50
- C 80
- D 90

CSG00244

- 47** The measures of the interior angles of a pentagon are $2x$, $6x$, $4x - 6$, $2x - 16$, and $6x + 2$. What is the measure, in degrees, of the largest angle?

- A 28
- B 106
- C 170
- D 174

CSG10028

- 48** What is $m\angle 1$?

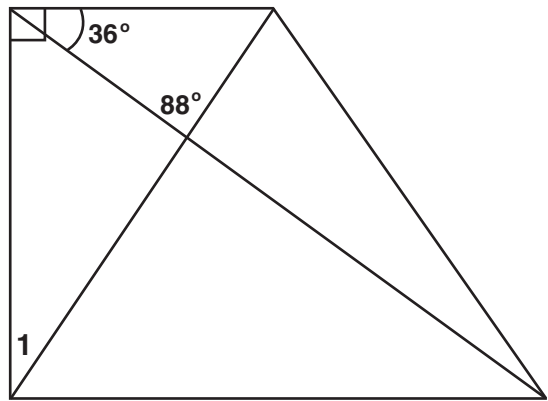

- A 34°
- B 56°
- C 64°
- D 92°

CSG20179

- 49** What is $m\angle WZX$?

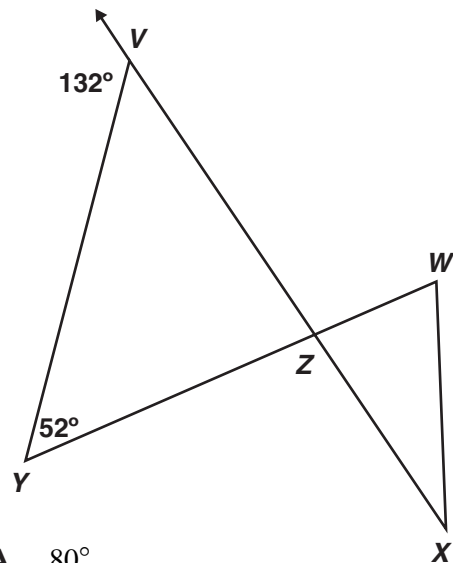

- A 80°
- B 90°
- C 100°
- D 110°

CSG30022

Released Test Questions

Geometry

50 What is the measure of an exterior angle of a regular hexagon?

- A 30°
- B 60°
- C 120°
- D 180°

CSG00570

51 A diagram from a proof of the Pythagorean theorem is pictured below.

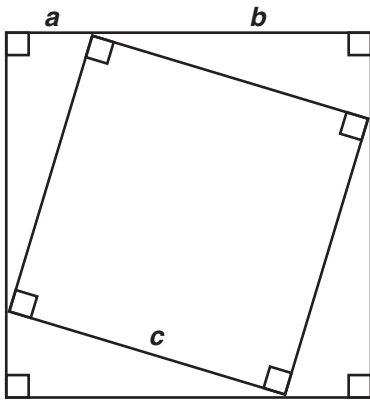

Which statement would *not* be used in the proof of the Pythagorean theorem?

- A The area of a triangle equals $\frac{1}{2}ab$.
- B The four right triangles are congruent.
- C The area of the inner square is equal to half of the area of the larger square.
- D The area of the larger square is equal to the sum of the areas of the smaller square and the four congruent triangles.

CSG10192

52 A right triangle's hypotenuse has length 5. If one leg has length 2, what is the length of the other leg?

- A 3
- B $\sqrt{21}$
- C $\sqrt{29}$
- D 7

CSG00566

53 A new pipeline is being constructed to re-route its oil flow around the exterior of a national wildlife preserve. The plan showing the old pipeline and the new route is shown below.

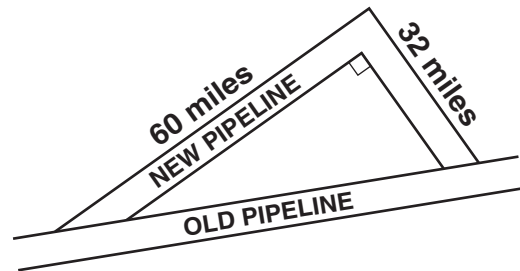

About how many extra miles will the oil flow once the new route is established?

- A 24
- B 68
- C 92
- D 160

CSG10016

Geometry

Released Test Questions

- 54** Marsha is using a straightedge and compass to do the construction shown below.

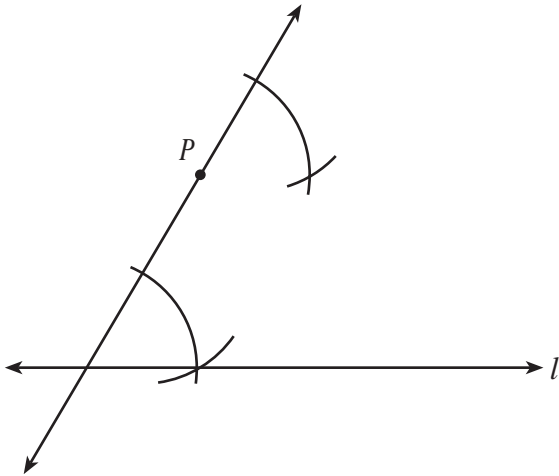

Which *best* describes the construction Marsha is doing?

- A a line through P parallel to line l
- B a line through P intersecting line l
- C a line through P congruent to line l
- D a line through P perpendicular to line l

CSG00526

- 55** Given: angle A

What is the first step in constructing the angle bisector of angle A ?

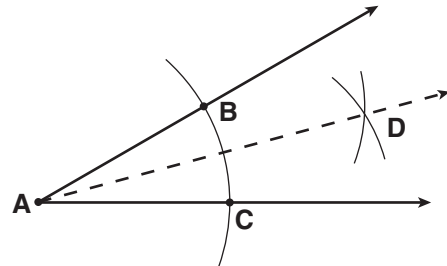

- A Draw ray \overline{AD} .
- B Draw a line segment connecting points B and C .
- C From points B and C , draw equal arcs that intersect at D .
- D From point A , draw an arc that intersects the sides of the angle at points B and C .

CSG10131

Released Test Questions

Geometry

- 56** Scott is constructing a line perpendicular to line l from point P . Which of the following should be his first step?

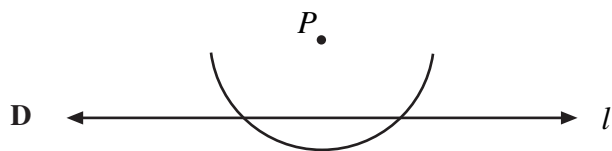
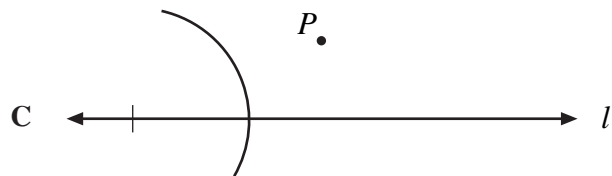
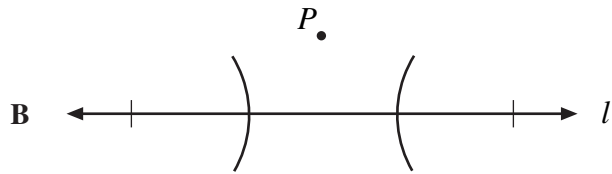
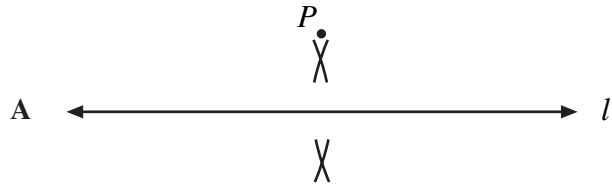

CSG00308

- 57** Which triangle can be constructed using the following steps?

1. Put the tip of the compass on point A .
2. Open the compass so that the pencil tip is on point B .
3. Draw an arc above \overline{AB} .
4. Without changing the opening, put the metal tip on point B and draw an arc intersecting the first arc at point C .
5. Draw \overline{AC} and \overline{BC} .

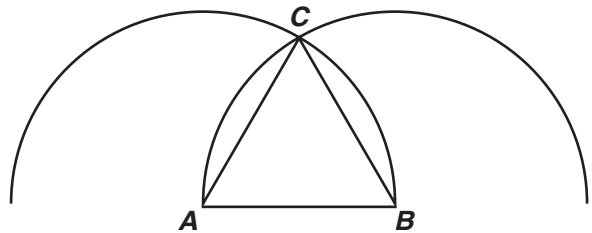

- A** right
- B** obtuse
- C** scalene
- D** equilateral

CSG10135

Geometry

Released Test Questions

- 58** The diagram shows $\triangle ABC$.

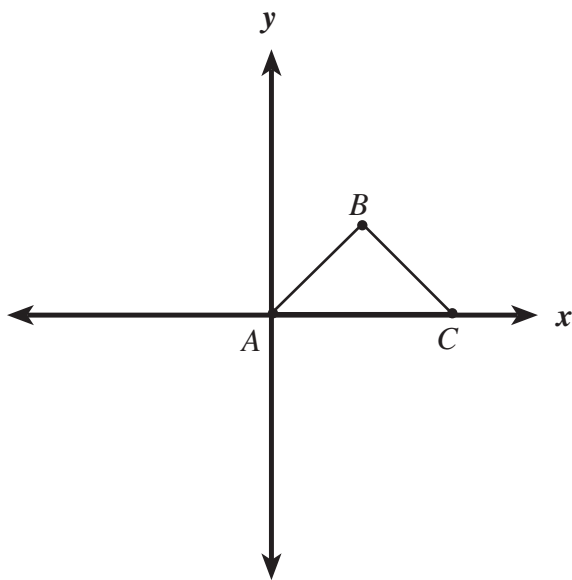

Which statement would prove that $\triangle ABC$ is a right triangle?

- A $(\text{slope } \overline{AB})(\text{slope } \overline{BC}) = 1$
 B $(\text{slope } \overline{AB})(\text{slope } \overline{BC}) = -1$
 C distance from A to B = distance from B to C
 D distance from A to B = $-$ (distance from B to C)

CSG00475

- 59** Figure $ABCO$ is a parallelogram.

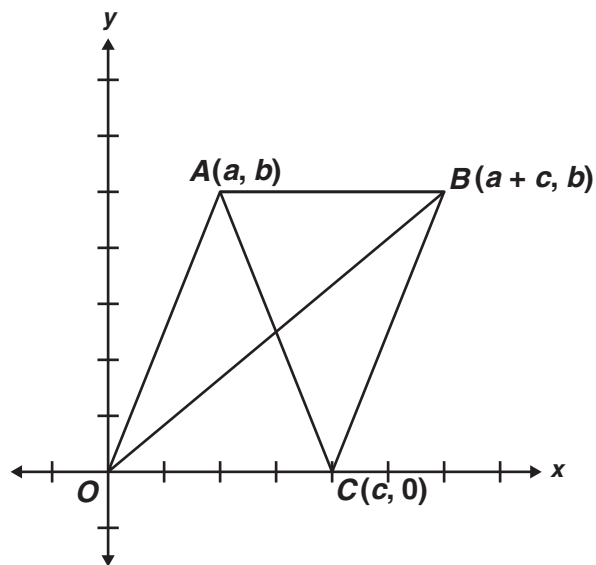

What are the coordinates of the point of intersection of the diagonals?

- A $\left(\frac{a}{2}, \frac{b}{2}\right)$
 B $\left(\frac{c}{2}, \frac{b}{2}\right)$
 C $\left(\frac{a+c}{2}, \frac{b}{2}\right)$
 D $\left(\frac{a+c}{2}, \frac{a+b}{2}\right)$

CSG20101

Released Test Questions

Geometry

- 60** What type of triangle is formed by the points $A(4,2)$, $B(6,-1)$, and $C(-1,3)$?

A right
 B equilateral
 C isosceles
 D scalene

CSG10235

- 61** The point $(-3, 2)$ lies on a circle whose equation is $(x + 3)^2 + (y + 1)^2 = r^2$. Which of the following must be the radius of the circle?

A 3
 B $\sqrt{10}$
 C 9
 D 10

CSG30048

- 62** In the figure below, if $\sin x = \frac{5}{13}$, what are $\cos x$ and $\tan x$?

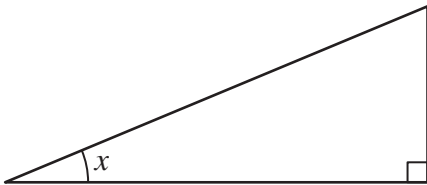

- A $\cos x = \frac{12}{13}$ and $\tan x = \frac{5}{12}$
 B $\cos x = \frac{12}{13}$ and $\tan x = \frac{12}{5}$
 C $\cos x = \frac{13}{12}$ and $\tan x = \frac{5}{12}$
 D $\cos x = \frac{13}{12}$ and $\tan x = \frac{13}{5}$

CSG00493

- 63** In the figure below, $\sin A = 0.7$.

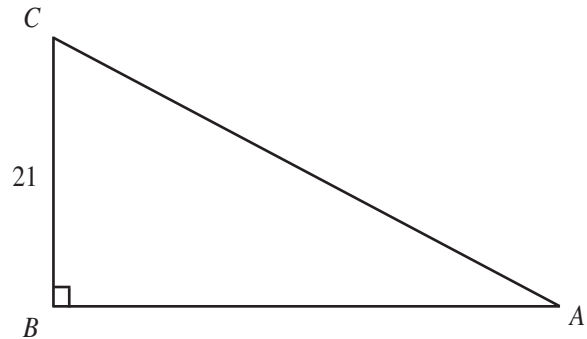

What is the length of \overline{AC} ?

- A 14.7
 B 21.7
 C 30
 D 32

CSG00432

Geometry

Released Test Questions

- 64 Approximately how many feet tall is the streetlight?

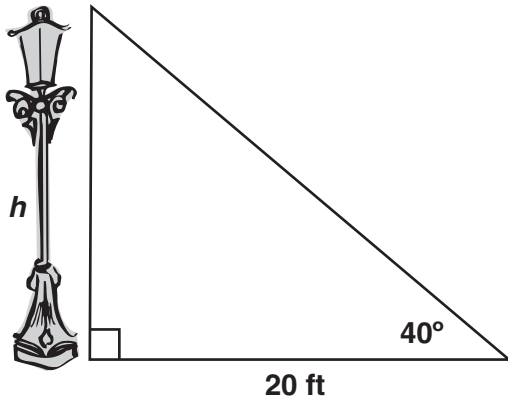

$\sin 40^\circ \approx 0.64$ $\cos 40^\circ \approx 0.77$ $\tan 40^\circ \approx 0.84$
--

- A 12.8
 B 15.4
 C 16.8
 D 23.8

CSG20047

- 65 Right triangle ABC is pictured below.

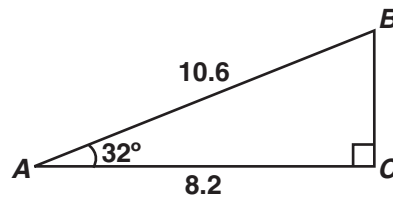

Which equation gives the correct value for BC ?

- A $\sin 32^\circ = \frac{BC}{8.2}$
 B $\cos 32^\circ = \frac{BC}{10.6}$
 C $\tan 58^\circ = \frac{8.2}{BC}$
 D $\sin 58^\circ = \frac{BC}{10.6}$

CSG10210

Released Test Questions

Geometry

- 66** In the accompanying diagram, $m\angle A = 32^\circ$ and $AC = 10$. Which equation could be used to find x in $\triangle ABC$?

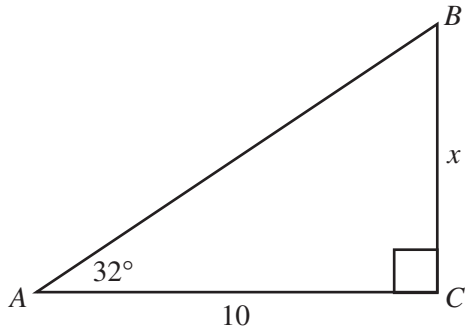

- A $x = 10 \sin 32^\circ$
- B $x = 10 \cos 32^\circ$
- C $x = 10 \tan 32^\circ$
- D $x = \frac{10}{\cos 32^\circ}$

CSG00555

- 67** The diagram shows an 8-foot ladder leaning against a wall. The ladder makes a 53° angle with the wall. Which is closest to the distance up the wall the ladder reaches?

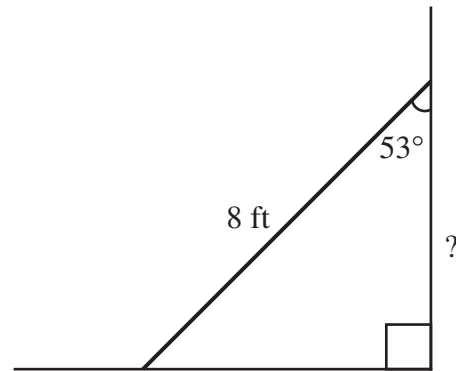

$\sin 53^\circ \approx 0.80$ $\cos 53^\circ \approx 0.60$ $\tan 53^\circ \approx 1.33$
--

- A 3.2 ft
- B 4.8 ft
- C 6.4 ft
- D 9.6 ft

CSG00342

Geometry

Released Test Questions

- 68 Triangle JKL is shown below.

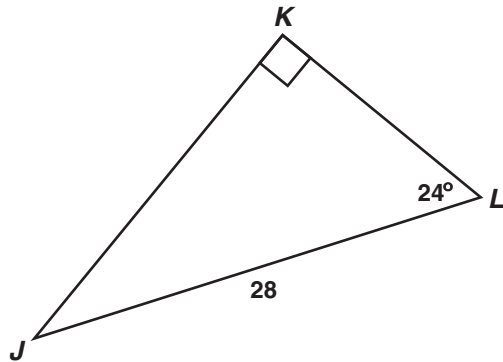

Which equation should be used to find the length of \overline{JK} ?

- A $\sin 24^\circ = \frac{JK}{28}$
 B $\sin 24^\circ = \frac{28}{JK}$
 C $\cos 24^\circ = \frac{JK}{28}$
 D $\cos 24^\circ = \frac{28}{JK}$

CSG20031

- 69 What is the approximate height, in feet, of the tree in the figure below?

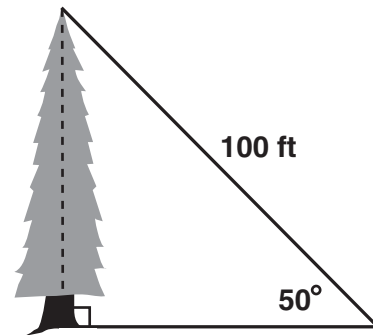

$$\begin{aligned}\sin 50^\circ &\approx 0.766 \\ \cos 50^\circ &\approx 0.643 \\ \tan 50^\circ &\approx 1.192\end{aligned}$$

- A 64.3
 B 76.6
 C 119.2
 D 130.5

CSG20126

- 70 If $a = 3\sqrt{3}$ in the right triangle below, what is the value of b ?

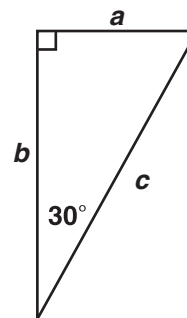

- A 9
 B $6\sqrt{3}$
 C $12\sqrt{3}$
 D 18

CSG10052

Released Test Questions

Geometry

71 What is the value of x in the triangle below?

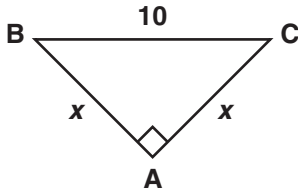

- A 5
- B $5\sqrt{2}$
- C $10\sqrt{3}$
- D 20

CSG10056

72 What is the value of x , in inches?

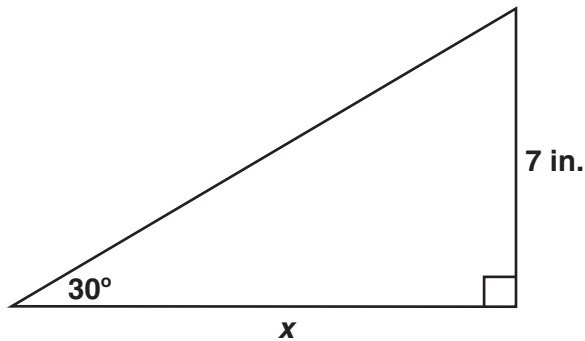

- A $7\sqrt{3}$
- B 14
- C $14\sqrt{3}$
- D 21

CSG20099

73 A square is circumscribed about a circle. What is the ratio of the area of the circle to the area of the square?

- A $\frac{1}{4}$
- B $\frac{1}{2}$
- C $\frac{2}{\pi}$
- D $\frac{\pi}{4}$

CSG00585

74 In the circle below, \overline{AB} and \overline{CD} are chords intersecting at E .

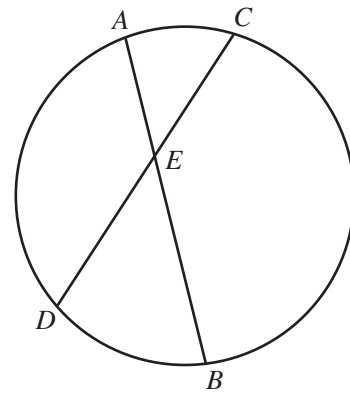

If $AE = 5$, $BE = 12$, and $CE = 6$, what is the length of \overline{DE} ?

- A 7
- B 9
- C 10
- D 13

CSG00022

Geometry

Released Test Questions

- 75 \overrightarrow{RB} is tangent to a circle, whose center is A , at point B . \overline{BD} is a diameter.

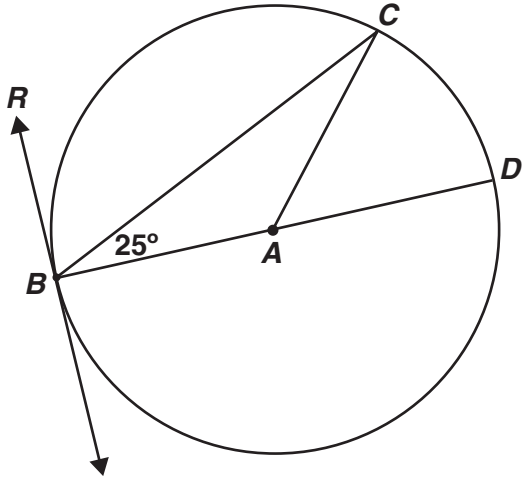

What is $m\angle CBR$?

- A 50°
- B 65°
- C 90°
- D 130°

CSG20186

- 76 In the figure below, \overline{AB} is tangent to circle O at point A , secant \overline{BD} intersects circle O at points C and D , $m\widehat{AC} = 70^\circ$, and $m\widehat{CD} = 110^\circ$.

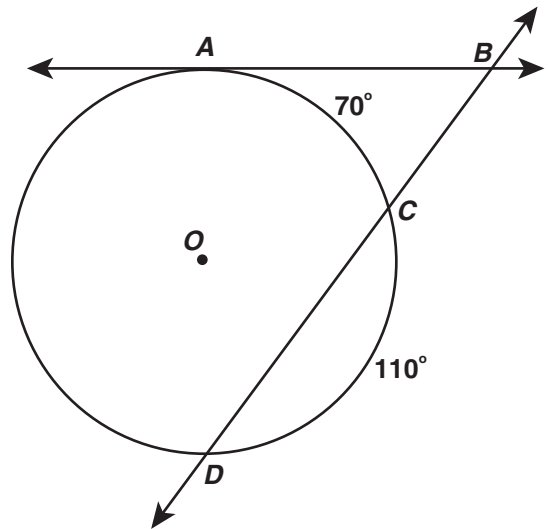

What is $m\angle ABC$?

- A 20°
- B 40°
- C 55°
- D 70°

CSG10257

Released Test Questions

Geometry

- 77** In the circle shown below, the measure of $\widehat{PR} = 140^\circ$ and the measure of $\angle RPQ = 50^\circ$.

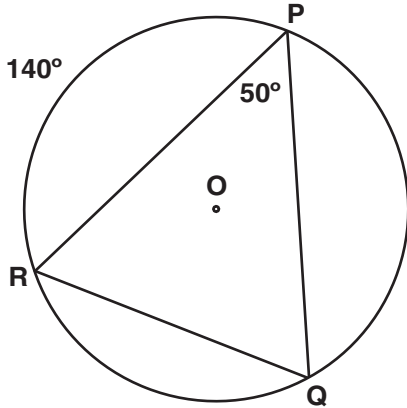

What is the measure of \widehat{PQ} ?

- A 50°
- B 60°
- C 70°
- D 120°

CSG10003

- 78** The vertices of $\triangle ABC$ are $A(2, 1)$, $B(3, 4)$, and $C(1, 3)$. If $\triangle ABC$ is translated 1 unit down and 3 units to the left to create $\triangle DEF$, what are the coordinates of the vertices of $\triangle DEF$?

- A $D(0, 1)$, $E(1, 2)$, $F(1, 3)$
- B $D(0, -1)$, $E(0, 3)$, $F(-2, -2)$
- C $D(-2, 2)$, $E(0, 3)$, $F(-1, 0)$
- D $D(-1, 0)$, $E(0, 3)$, $F(-2, 2)$

CSG00317

- 79** If triangle ABC is rotated 180 degrees about the origin, what are the coordinates of A' ?

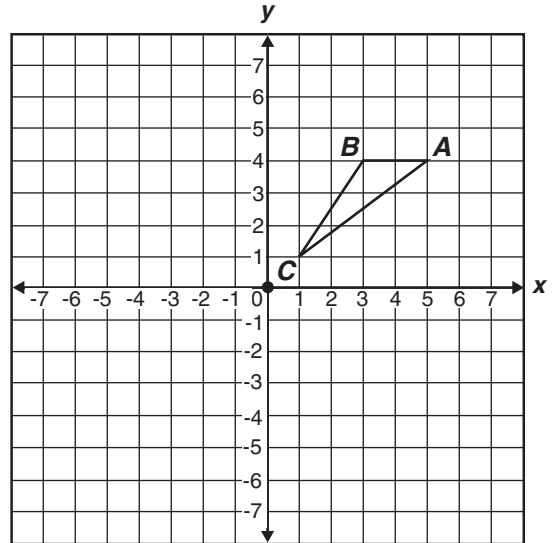

- A $(-5, -4)$
- B $(-5, 4)$
- C $(-4, 5)$
- D $(-4, -5)$

CSG10096

Geometry

Released Test Questions

- 80** Trapezoid $ABCD$ below is to be translated to trapezoid $A'B'C'D'$ by the following motion rule.

$$(x, y) \rightarrow (x + 3, y - 4)$$

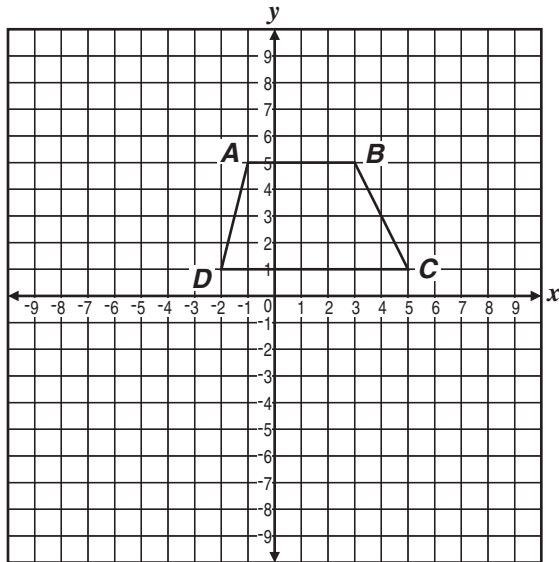

What will be the coordinates of vertex C' ?

- A $(1, -3)$
- B $(2, 1)$
- C $(6, 1)$
- D $(8, -3)$

CSG10214

Question Number	Correct Answer	Standard	Year of Release
1	A	GE1.0	2004
2	A	GE1.0	2005
3	C	GE1.0	2007
4	D	GE2.0	2003
5	D	GE2.0	2004
6	D	GE2.0	2005
7	B	GE2.0	2007
8	B	GE3.0	2003
9	D	GE3.0	2004
10	C	GE3.0	2005
11	A	GE3.0	2006
12	D	GE4.0	2003
13	C	GE4.0	2004
14	C	GE4.0	2005
15	B	GE4.0	2005
16	D	GE4.0	2006
17	A	GE4.0	2007
18	D	GE4.0	2007
19	A	GE5.0	2003
20	A	GE5.0	2004
21	C	GE6.0	2003
22	B	GE6.0	2007
23	C	GE7.0	2003
24	B	GE7.0	2004
25	C	GE7.0	2005
26	D	GE7.0	2006
27	A	GE7.0	2006
28	D	GE8.0	2003
29	C	GE8.0	2005
30	C	GE8.0	2006
31	C	GE8.0	2007
32	A	GE9.0	2006
33	D	GE9.0	2006
34	C	GE10.0	2003
35	A	GE10.0	2004

Question Number	Correct Answer	Standard	Year of Release
36	<i>C</i>	GE10.0	2005
37	<i>B</i>	GE10.0	2006
38	<i>B</i>	GE10.0	2007
39	<i>B</i>	GE10.0	2007
40	<i>D</i>	GE11.0	2004
41	<i>A</i>	GE11.0	2005
42	<i>D</i>	GE12.0	2003
43	<i>A</i>	GE12.0	2003
44	<i>C</i>	GE12.0	2005
45	<i>A</i>	GE12.0	2005
46	<i>D</i>	GE12.0	2006
47	<i>C</i>	GE12.0	2007
48	<i>A</i>	GE13.0	2005
49	<i>A</i>	GE13.0	2006
50	<i>B</i>	GE13.0	2007
51	<i>C</i>	GE14.0	2004
52	<i>B</i>	GE15.0	2003
53	<i>A</i>	GE15.0	2004
54	<i>A</i>	GE16.0	2003
55	<i>D</i>	GE16.0	2004
56	<i>D</i>	GE16.0	2006
57	<i>D</i>	GE16.0	2007
58	<i>B</i>	GE17.0	2004
59	<i>C</i>	GE17.0	2005
60	<i>D</i>	GE17.0	2006
61	<i>A</i>	GE17.0	2007
62	<i>A</i>	GE18.0	2003
63	<i>C</i>	GE18.0	2004
64	<i>C</i>	GE18.0	2006
65	<i>C</i>	GE18.0	2007
66	<i>C</i>	GE19.0	2003
67	<i>B</i>	GE19.0	2005
68	<i>A</i>	GE19.0	2006
69	<i>B</i>	GE19.0	2007
70	<i>A</i>	GE20.0	2004

Question Number	Correct Answer	Standard	Year of Release
71	<i>B</i>	GE20.0	2005
72	<i>A</i>	GE20.0	2007
73	<i>D</i>	GE21.0	2003
74	<i>C</i>	GE21.0	2004
75	<i>B</i>	GE21.0	2005
76	<i>C</i>	GE21.0	2006
77	<i>D</i>	GE21.0	2007
78	<i>D</i>	GE22.0	2003
79	<i>A</i>	GE22.0	2004
80	<i>D</i>	GE22.0	2006